

INTRODUCTION

- Quantum repeaters (QRs) can overcome the exponential scaling of loss with distance in an optical fiber by using quantum memory (QM) and entanglement swapping [1] and thus provide an avenue to long-distance quantum communication.
- Quantum memory and quantum entanglement light source are the two essential components of a quantum repeater, both can be realized by atomic ensembles or single-atom systems.
- The multi-mode quantum repeater based on the absorptive quantum memory is a high-speed quantum repeater architecture, since it's compatible with the atomic ensemble-based multi-mode quantum memory and the single-atom-based deterministic entanglement source at the same time [2].
- Quantum storage of the deterministic entanglement source is a key step towards practical applications of this quantum repeater architecture, which has not yet been realized. Here we present a deterministic entanglement light source based on the semiconductor quantum dots, which is compatible with ytterbium-doped broadband quantum memory, intend to achieve multi-mode entanglement storage.

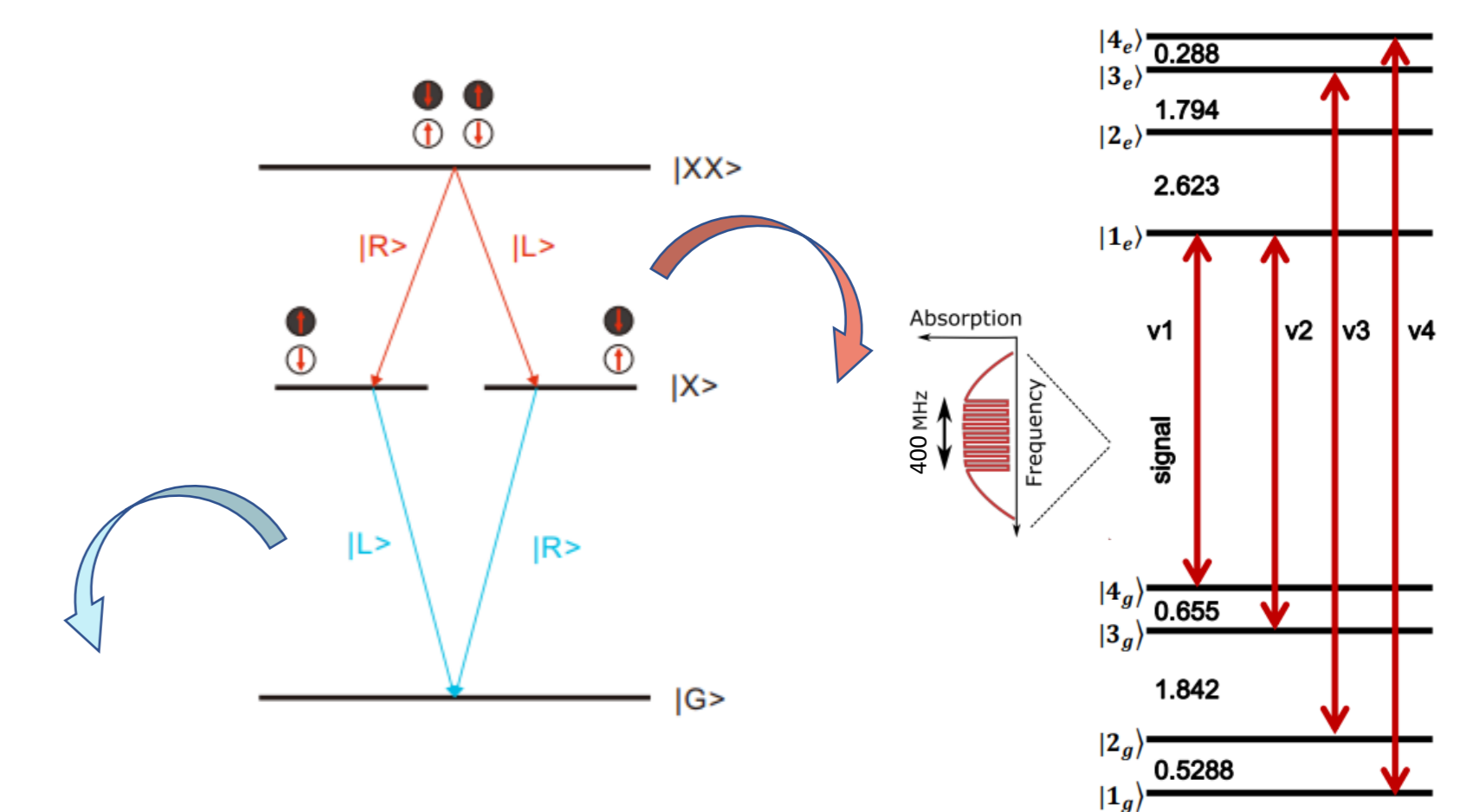

FIG1. The combination of deterministic entanglement sources and multiplexed absorptive quantum memories.

EXPERIMENTAL SETUP

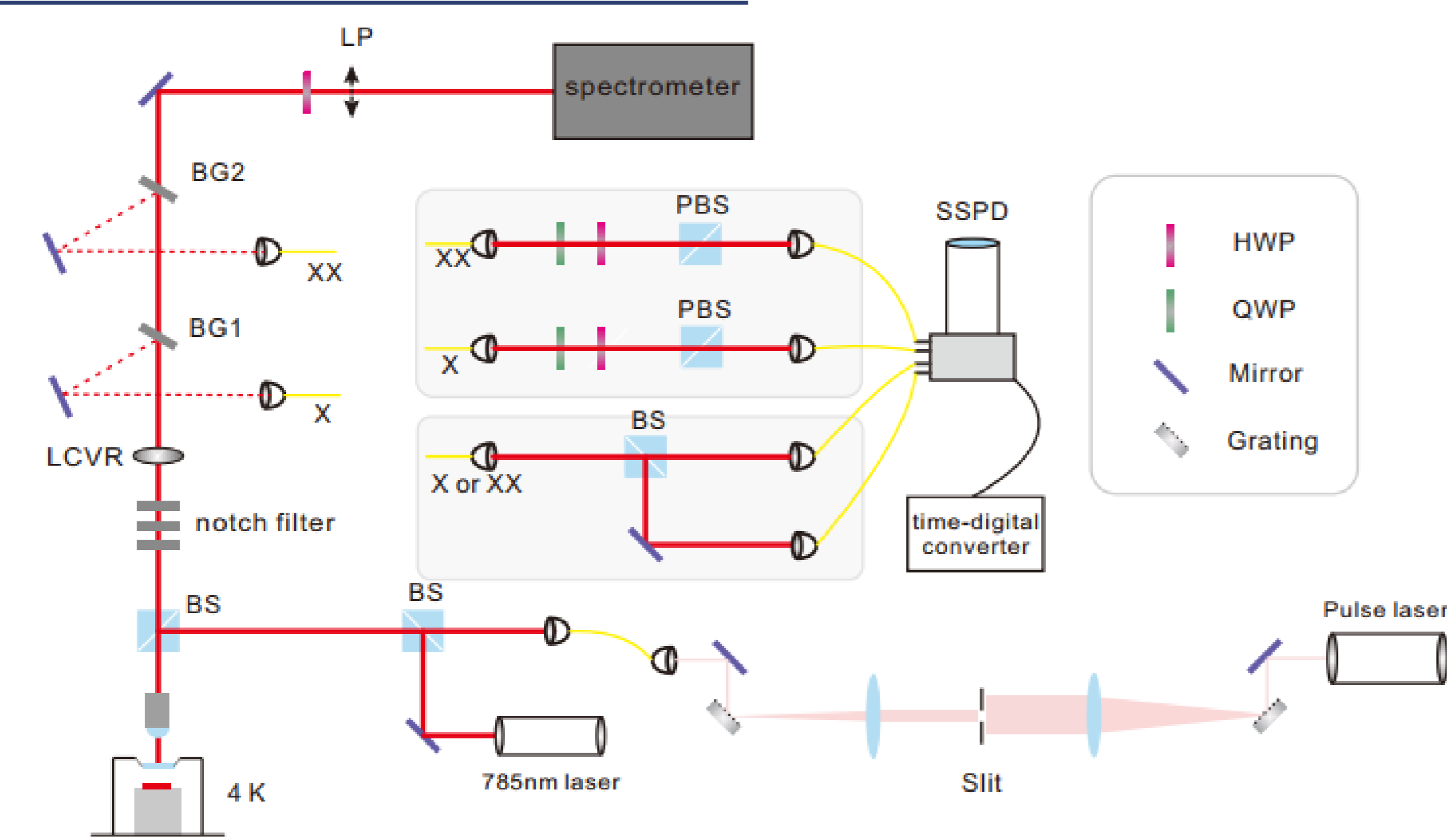

FIG2. Experimental setup.

- In the experiment, we use two lasers for above-band excitation and two-photon resonance excitation respectively.
- The sample is placed in a 4 K Montana cryogenic chamber with a three-axis displacement stage that can be used to search for luminescent quantum dots. The laser is focused onto the sample through a window-collimated objective with a numerical aperture NA=0.65. A long-pass filter (LPF) added to the collection light path to remove the excitation light.
- By fine-tuning the angle of the Bragg gratings, excitons and biexcitons can be accurately reflected, and the two photons are collected and sent to the subsequent optical path for single photon measurement and entanglement measurement.

RESULTS

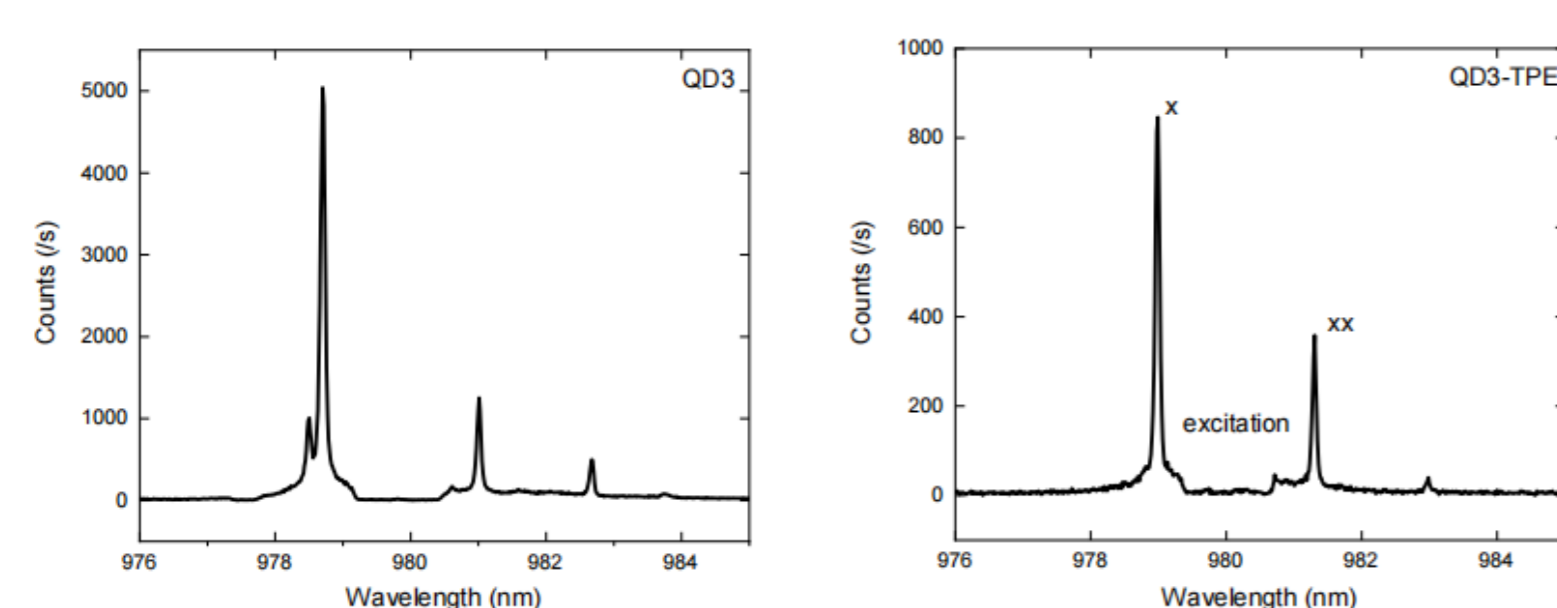

FIG3. Spectral results of above-band excitation and two-photon excitation.

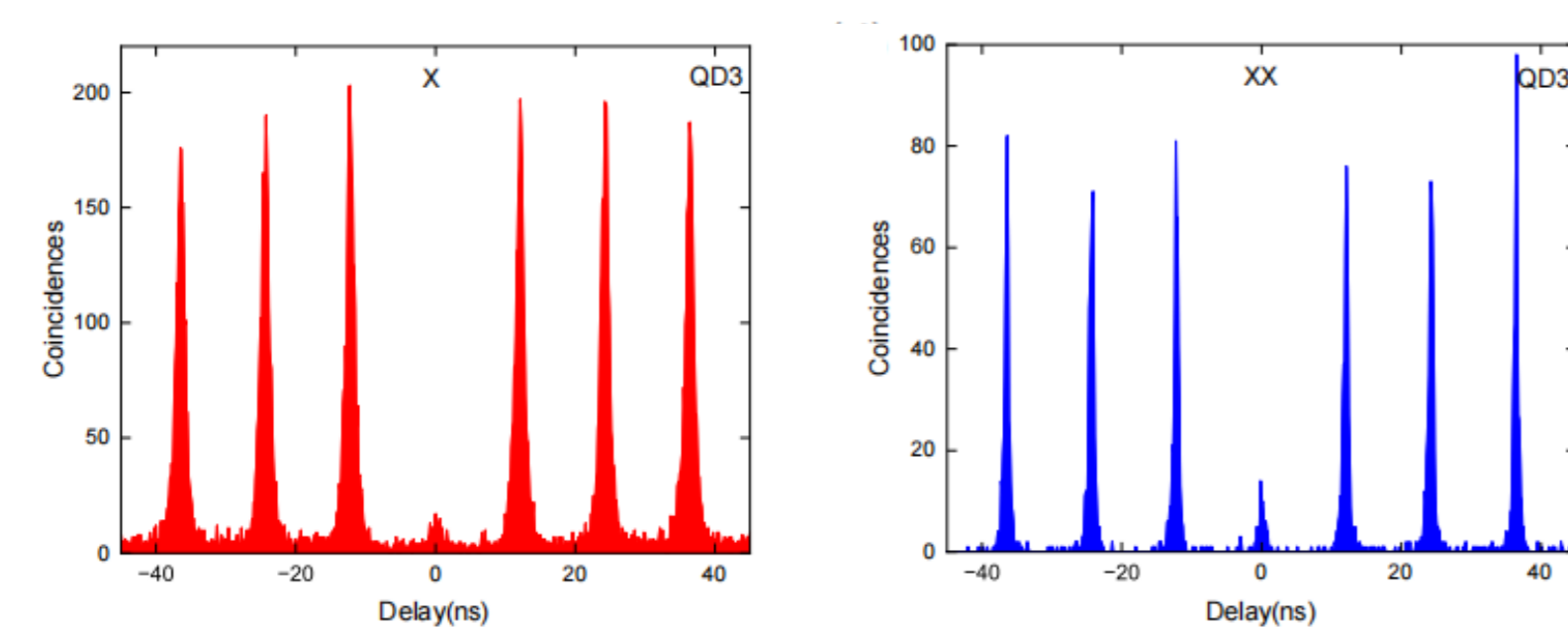
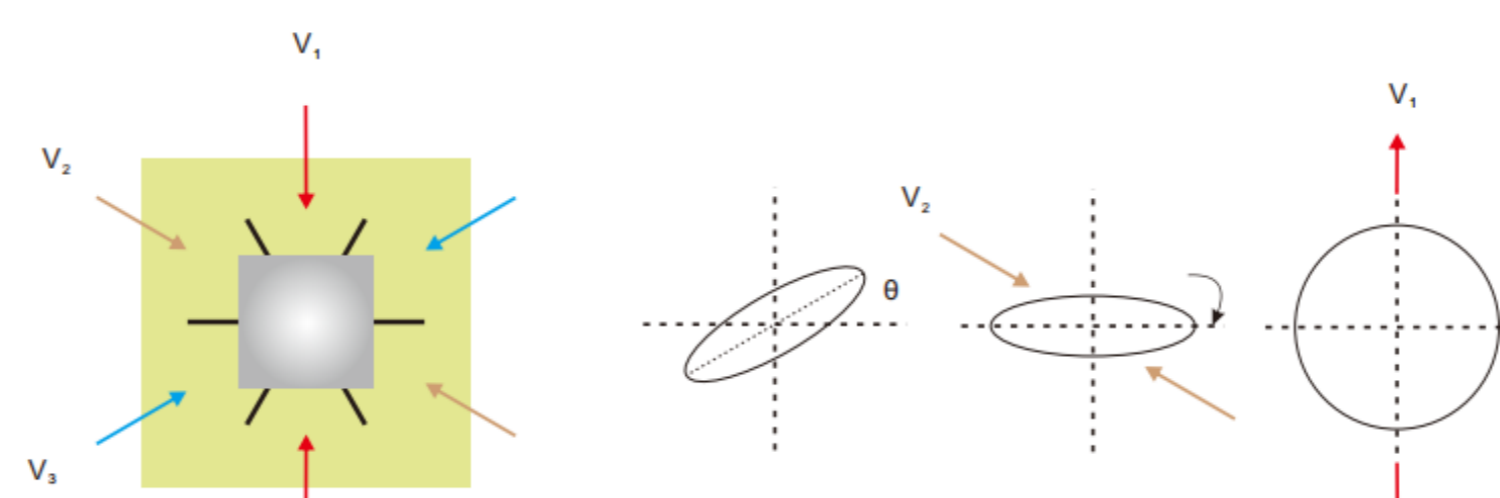
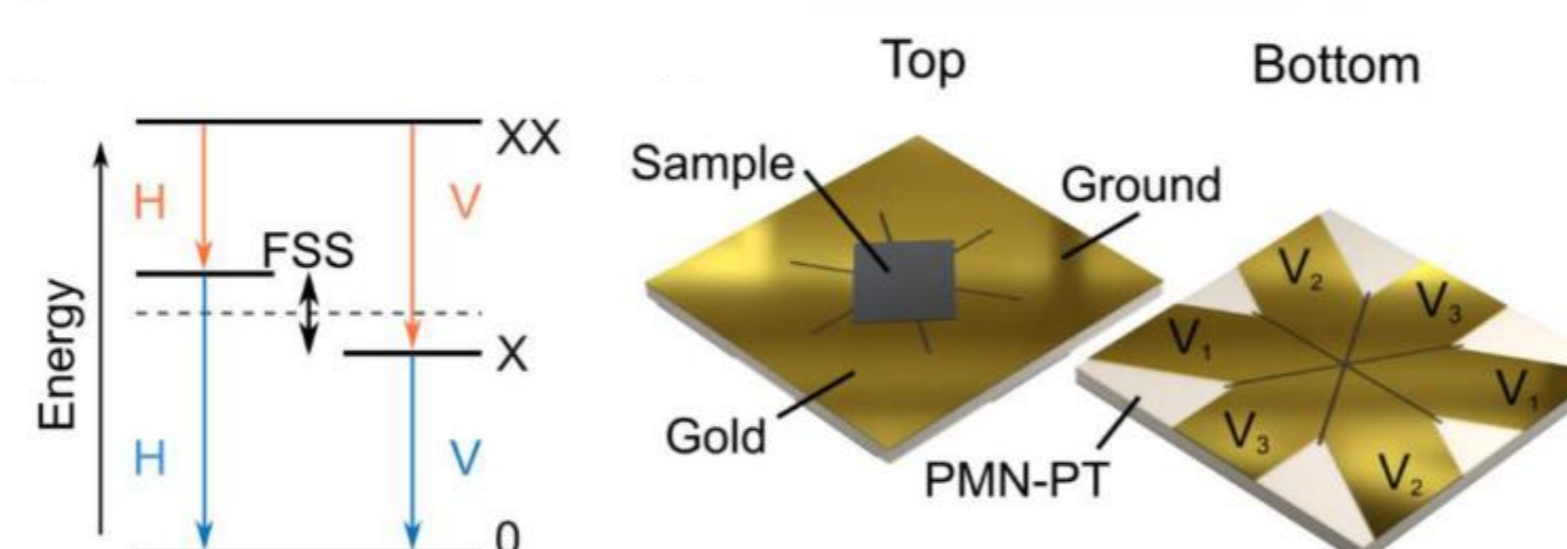

FIG4. Single-photon properties of the exciton and biexciton.



$$H(\mathbf{n}, p) = H_{2v} + V_1 + V_s(\mathbf{n})p$$

FIG5. Tuning fine structure splitting and wavelength using three non-coaxial stresses.

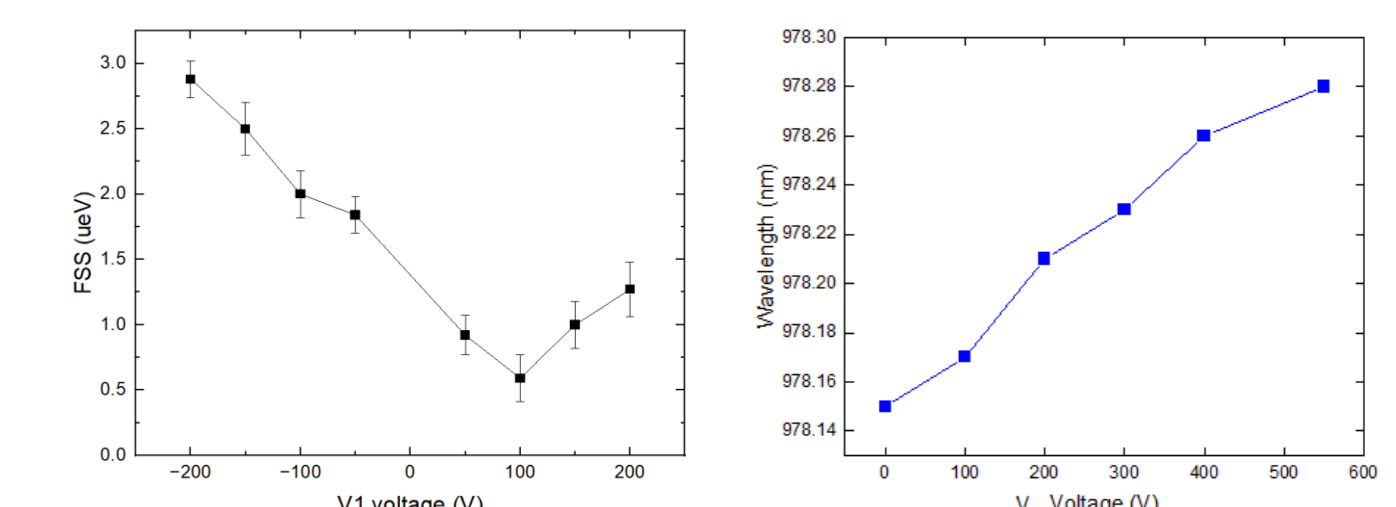

FIG6. Tuning fine structure splitting and wavelength.

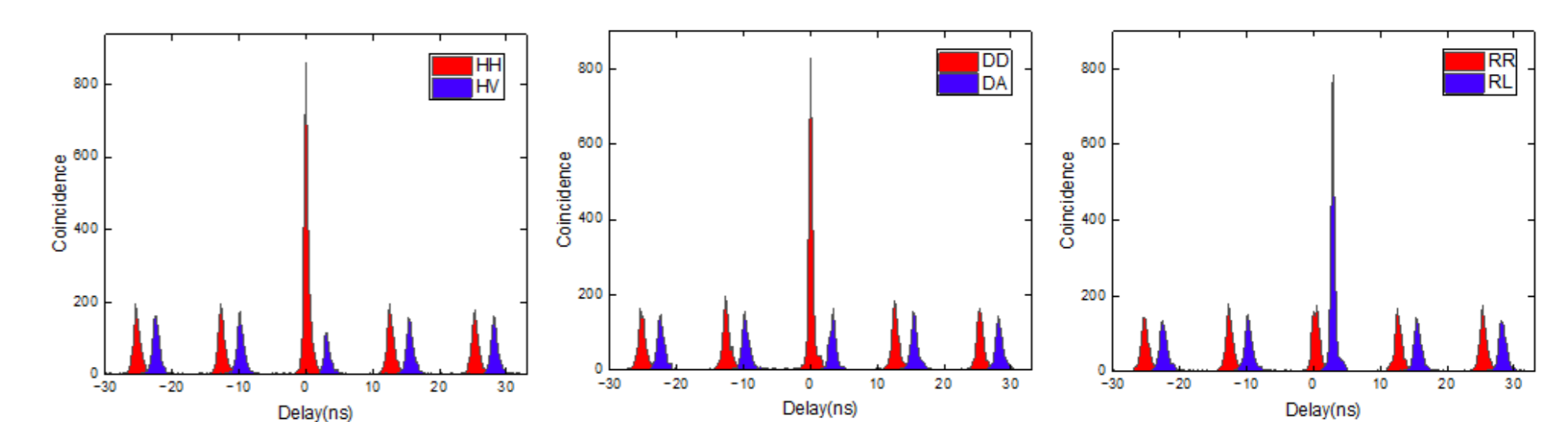

FIG7. Verification of entanglement fidelity between exciton-biexciton.

$$\mathcal{F} \sim 80.5\%$$

CONCLUSION & OUTLOOK

Conclusion

- We have successfully developed a suitable deterministic quantum light source based on InAs quantum dots which is compatible with absorptive quantum memories, and obtain polarization-entangled photon pairs utilized two-photon resonance excitation.
- We also tune the fine-structure splitting and the radiation wavelength of quantum dots via external stress, laying the foundation for the realization of multi-mode storage of deterministic entangled photons.

Outlook

- The wideband quantum memory based on Yb: YSO crystal was in progress, which can store an arbitrary polarization state with a storage bandwidth of 400 MHz.
- The combination of deterministic entanglement sources and multiplexed absorptive quantum memories would enable efficient quantum repeaters and scalable quantum networks [3].

REFERENCE

- Briegel, H.-J. et al. Phys. Rev. Lett. 81, 5932–5935 (1998).
- Liu, X. et al. Nature 594, 41–45 (2021).
- Tang, J.-S. et al. Nat. Commun. 6, 8652 (2015).

CONTACT

Jun Hu
Email: hujun218@ustc.edu.cn