

Differential Mach-Zehnder Interferometry With Trapped BECs

A. Santoni⁴, T. Petrucciani¹, C. Mazinghi¹, D. Trypogeorgos³, L. Pezzé¹, A. Smerzi¹, F. Cataliotti^{1,2}, M. Inguscio¹, G. Modugno^{1,2} and M. Fattori^{1,2}

- [1] National Institute of Optics (CNR-INO), Sesto Fiorentino, Italy
- [2] Physics and Astronomy Department, University of Florence, Sesto Fiorentino, Italy
- [3] CNR NANOTEC, Institute of Nanotechnology, Lecce, Italy
- [4] University of Naples "Federico II", Via Cinthia 21, 80126 Napoli, Italy

Our experiment consists of an array of trapped atom double well (DW) interferometers using ³⁹K Bose Einstein condensates. Implementing an optical superlattice potential, we create several interferometers working simultaneously. The novelty of our setup consists in the use of three standard 1D lattices with lasers retroreflected on a common mirror, that realize a new kind of beat note potential [1]. Such configuration is intrinsically very stable because it depends on the stability of the mirror and of the laser frequencies, like in state of the art free falling atom interferometers [2,3]. Cancelling interparticle interactions using a broad magnetic Feshbach resonance we demonstrate the operation of linear Mach-Zehnder interferometers with trapped BECs. By a differential analysis on two interferometers operating in parallel, we demonstrate for the first time a trapped atom gradiometer.

Mach-Zehnder Interferometer with Double-well potential

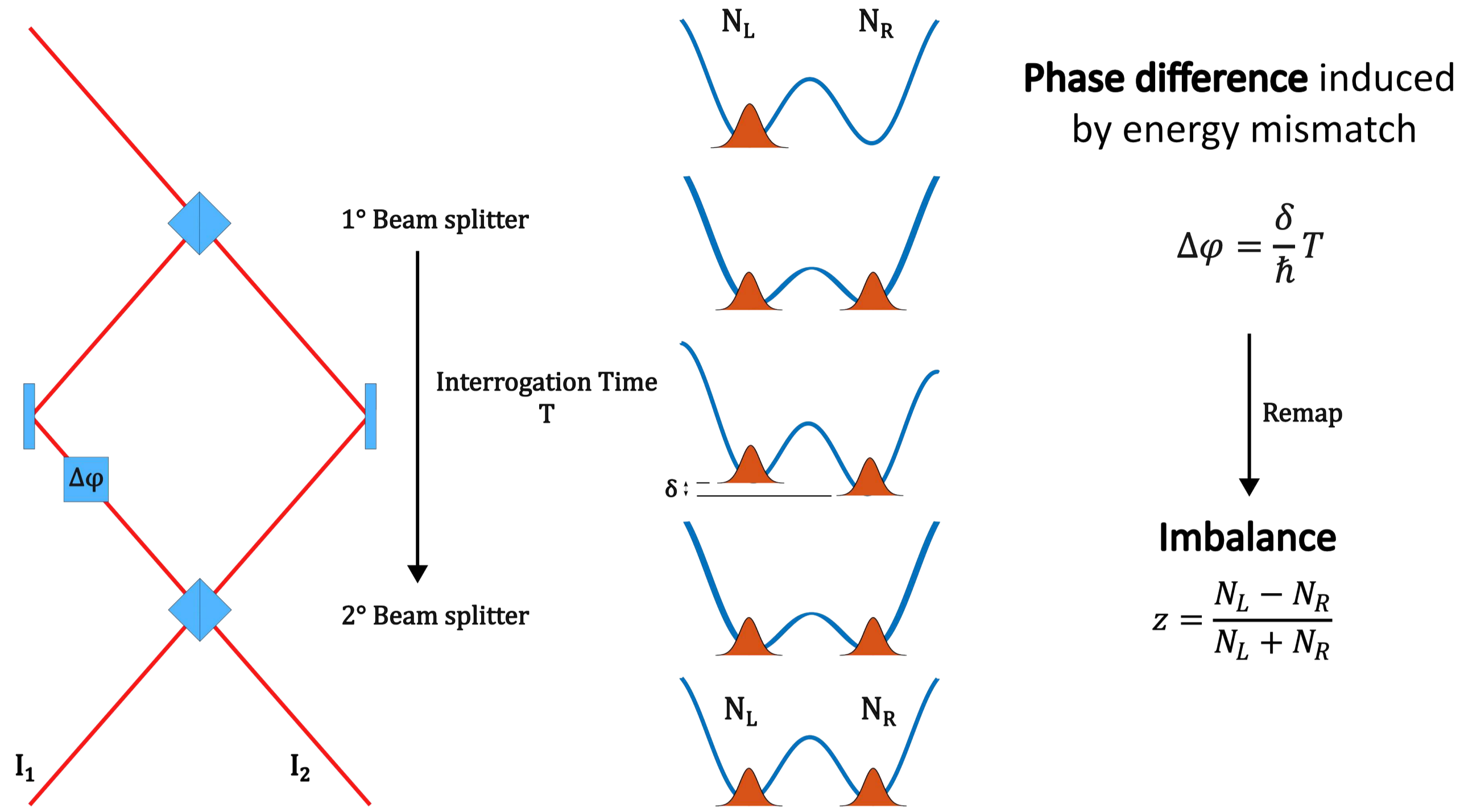

Double-well potential using Beat note lattices

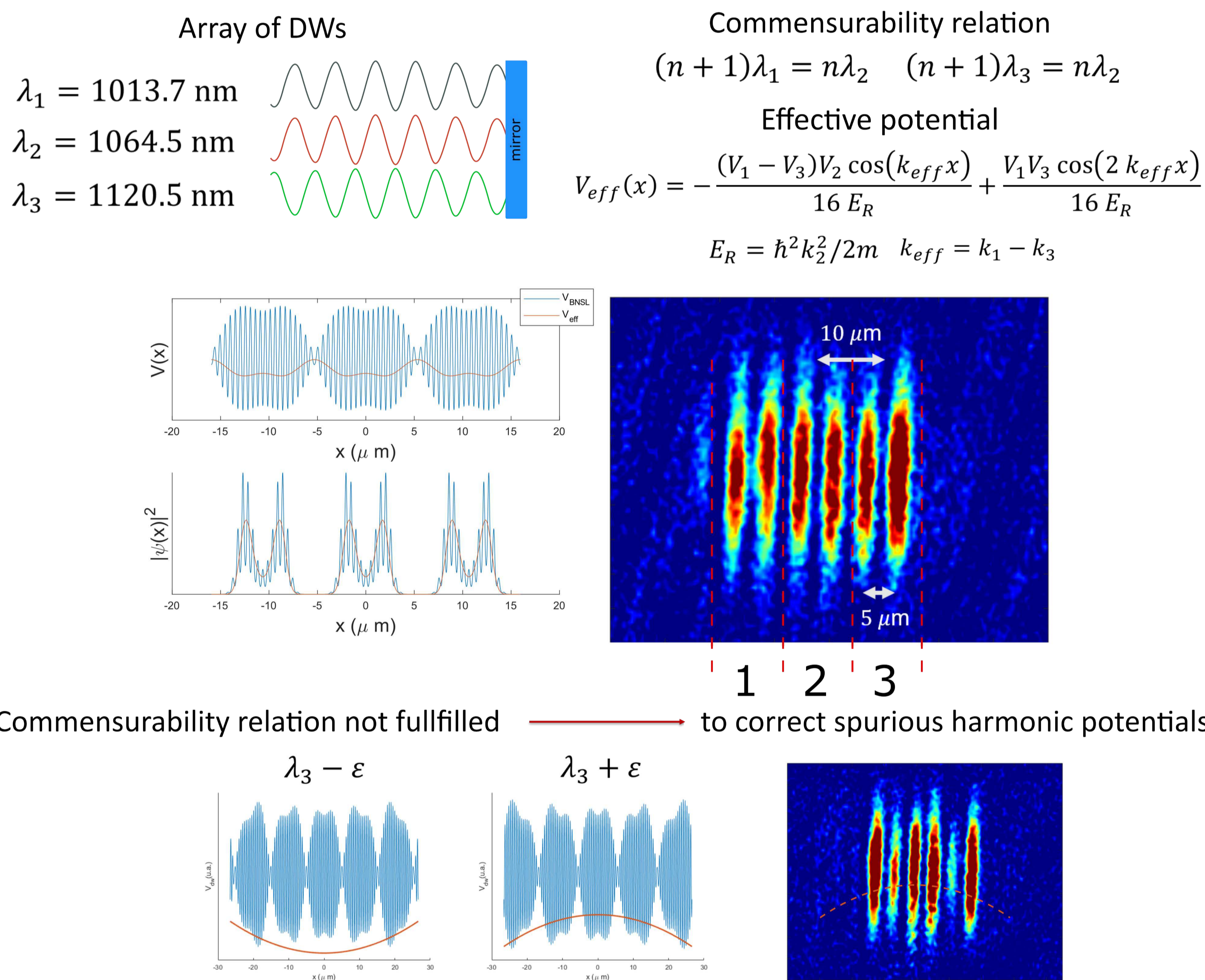

Mach-Zehnder Gradiometer

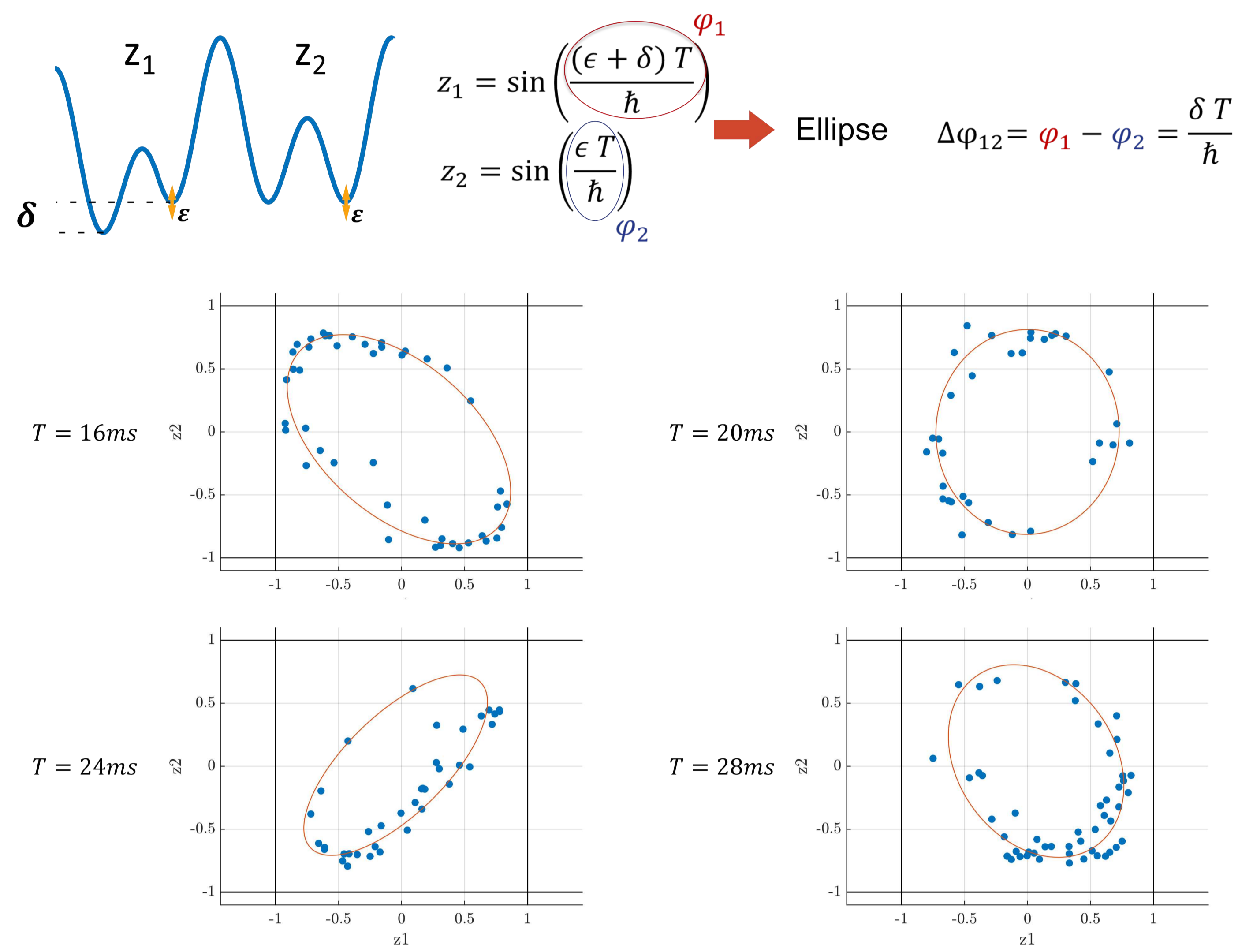

To study the system we add a known harmonic trap

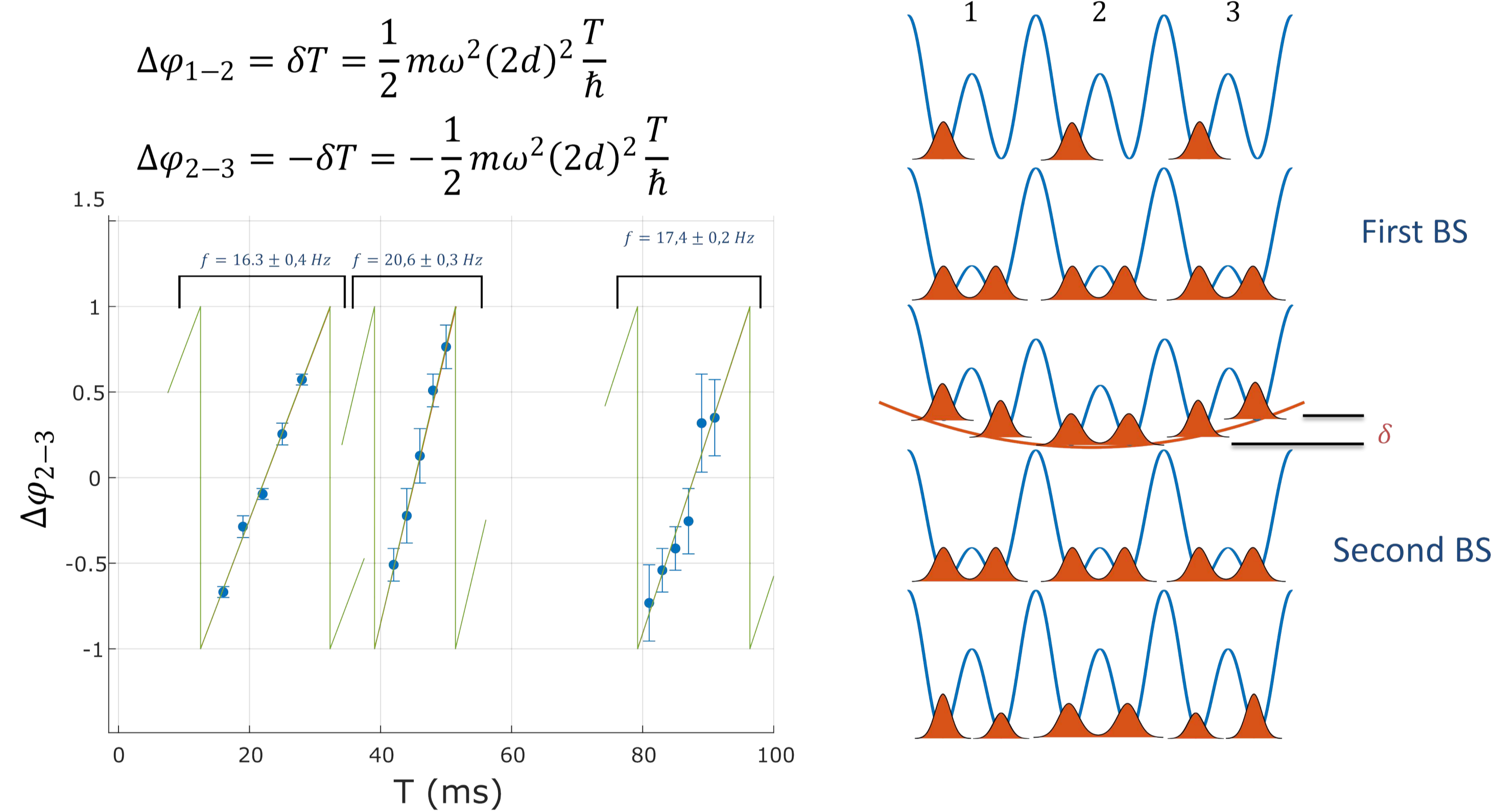

Trapped Atom Gradiometer

Tunneling in the double-well

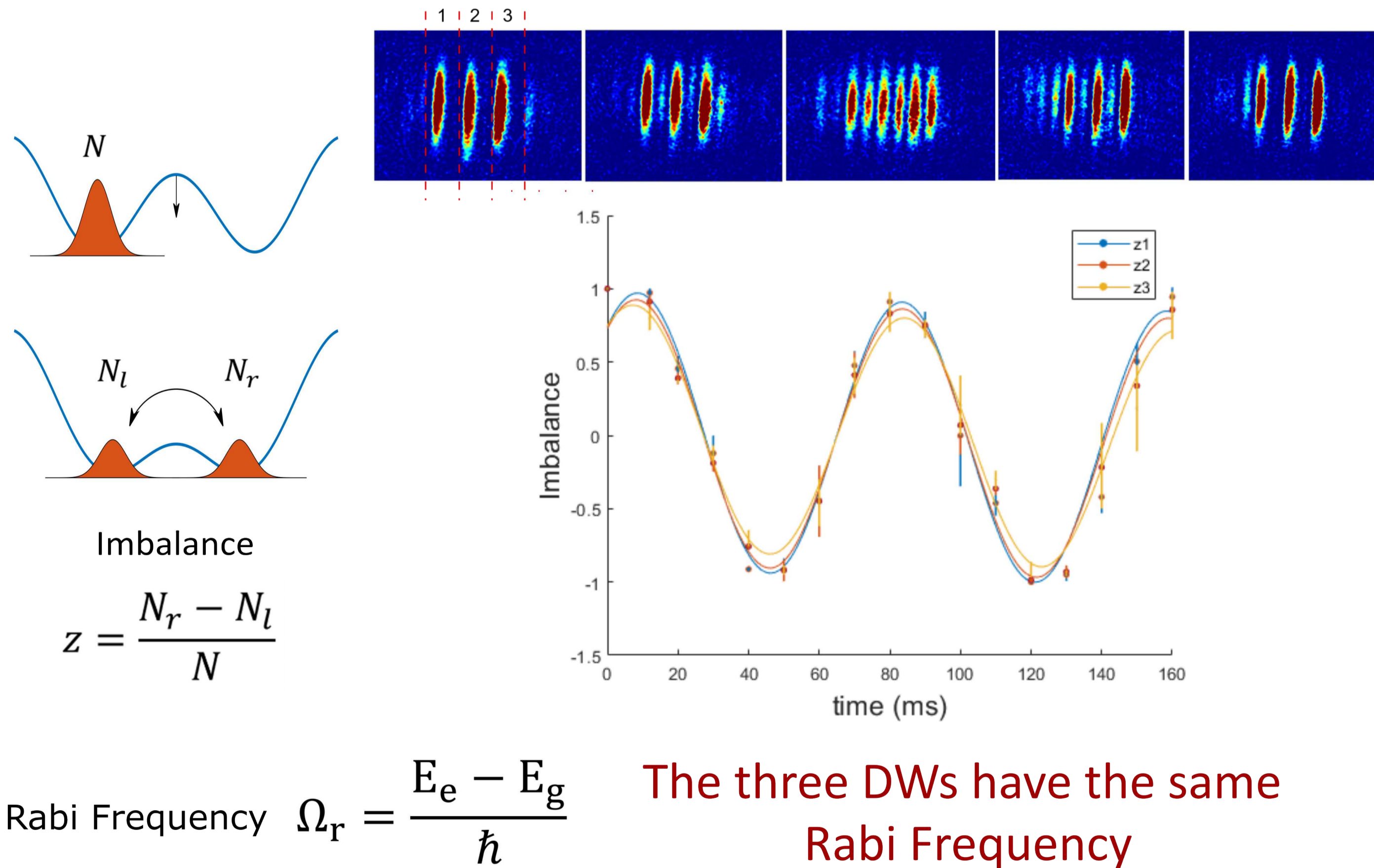

Coherence

we study $\text{var}(\Delta\phi)$ at different times

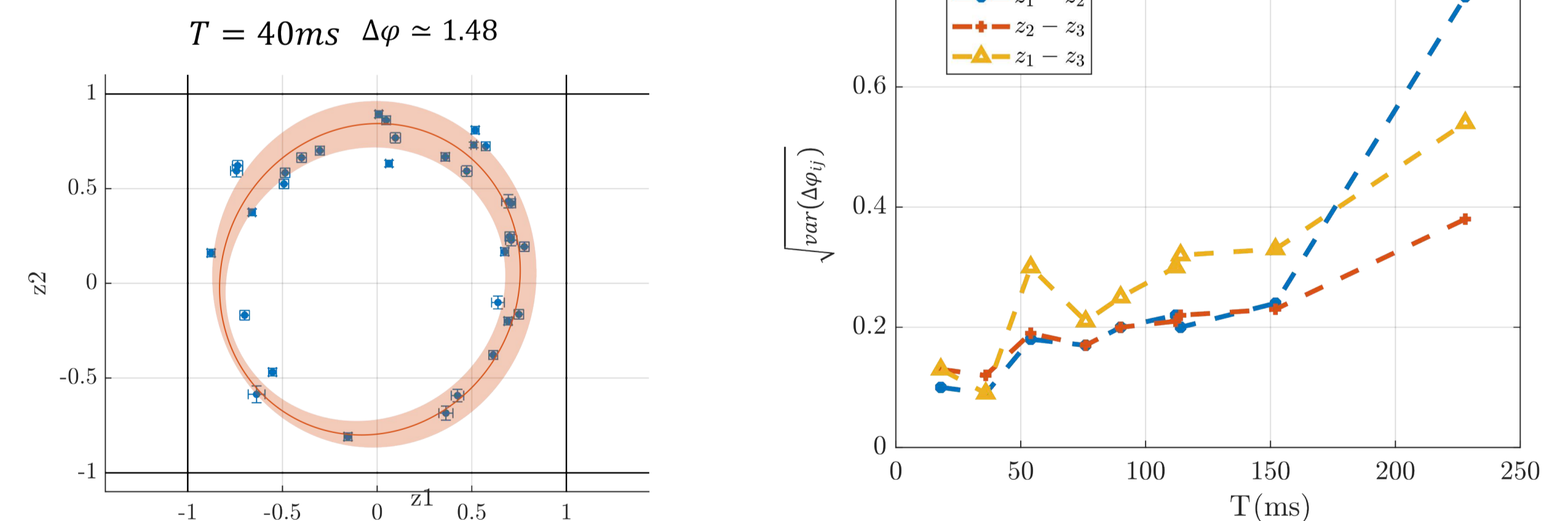

Spin-Echo

Spin echo cancels the low frequency noise in each interferometer, while the differential analysis cancel the common frequency noise.

Spin-echo + gradiometer coherence is affected by:

- 1) Not common AC noise
- 2) Decoherence caused by interactions

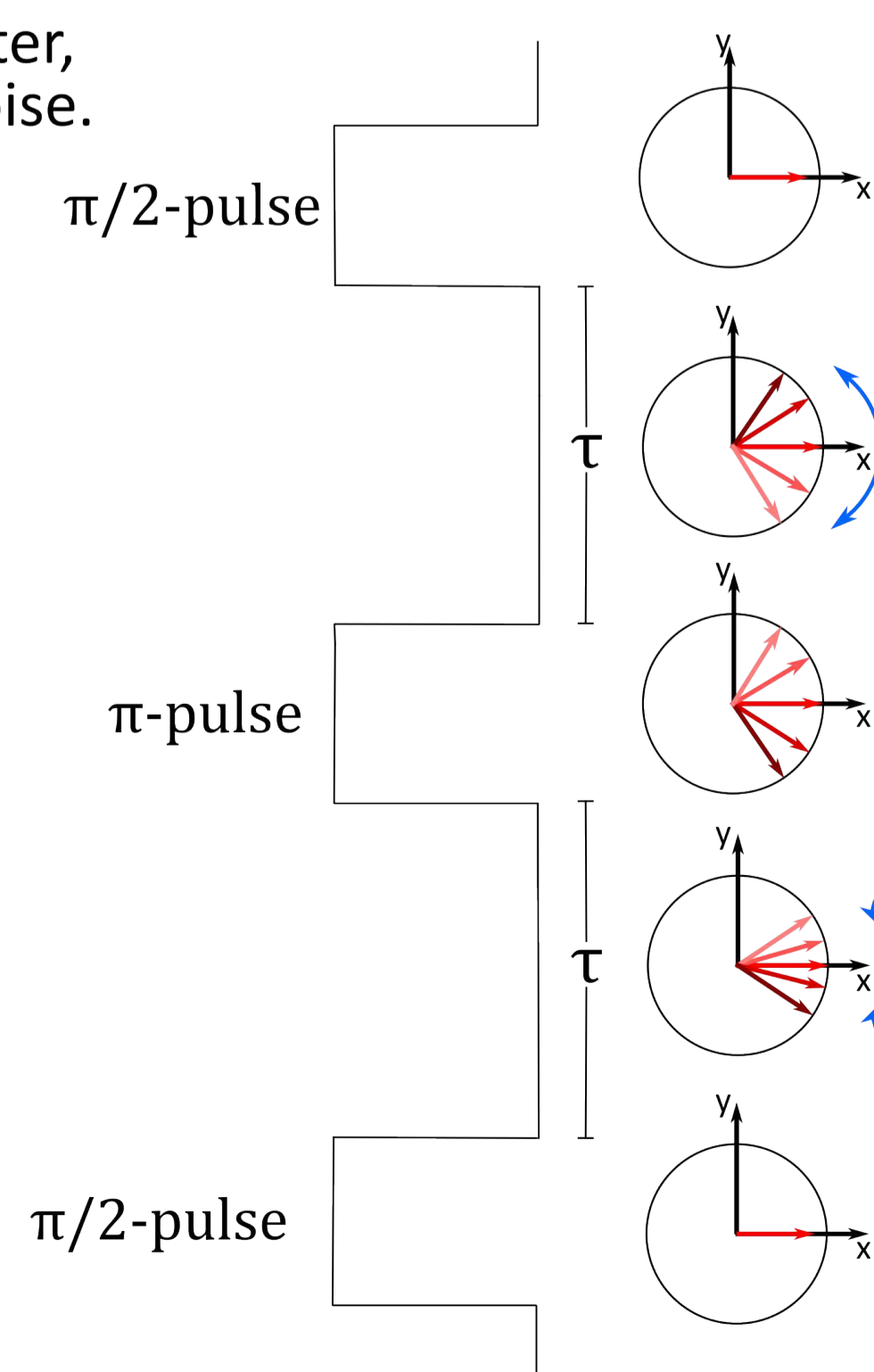
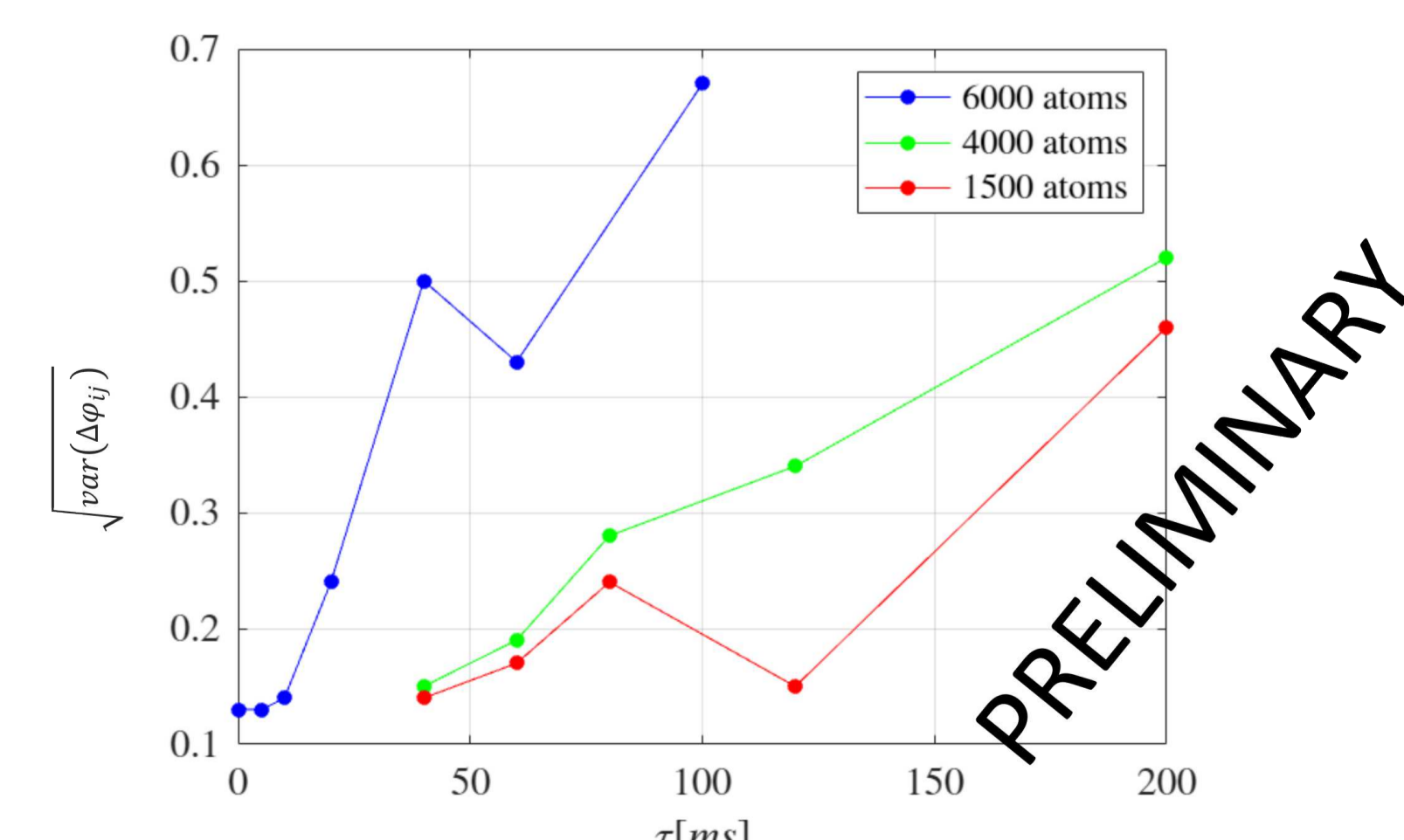

Open questions:

- Main sources of decoherence
- Study of residual interactions (three body collisions?)
- Can we cancel extra noise from analysis on three or more interferometers?

References

- [1] Masi, L., et al. "Spatial Bloch Oscillations of a Quantum Gas in a "Beat-Note" Superlattice." Physical Review Letters 127.2 (2021): 020601.
- [2] Peters, Achim, Keng Yeow Chung, and Steven Chu. "Measurement of gravitational acceleration by dropping atoms." Nature 400.6747 (1999): 849-852.
- [3] Shin, Y., et al. "Atom interferometry with Bose-Einstein condensates in a double-well potential." Physical review letters 92.5 (2004): 050405.



This project has received funding from the European Union's Horizon 2020 Research and Innovation Programme under Grant Agreement no. 731473 and 101017733.